

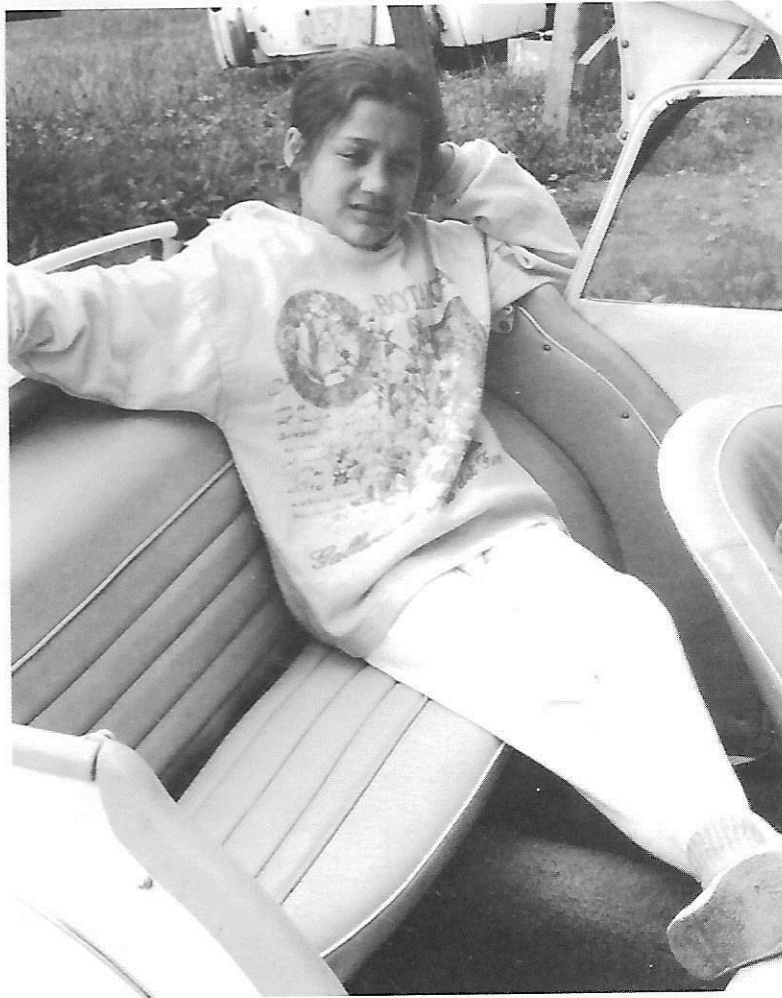

# NATIONAL NEWSLETTER

VOLUME 15 NUMBER 4  
ISSUE NUMBER 64



**Occasional Seats!**

# 'FORMED TO PRESERVE THE MARQUE'

The **Triumph Register of America** is the only national U.S. organization devoted solely to the TR2/3 series. TRA was established to aid TR2/3 owners in the preservation of their classic cars.

For membership information contact the membership chairperson. Dues are \$15 per 4 issues of the newsletter.

## OFFICERS:

**President:** Joe Richards, 614-756-4575  
5650 Brook Rd., NW, Lancaster, OH 43130

**Treasurer:** Joe Richards, 614-756-4575  
5650 Brook Rd., NW, Lancaster, OH 43130

**Membership Chairperson:** John Warfield, Suite TR3  
OH 43130  
1-410-974-6707  
See President's Message for details!

**Local Center C:** Susie House, 614-753-1066  
151 Parkview Dr., Nelsonville, OH 4312

**Newsletter Editor:** John Huddy  
1-614-846-2321  
See Next page for details!

**Historian:**

## COMMITTEES:

**National Meet Coordinator:** Bruce Clough, 513-294-3111  
3207 Oakmont Ave., Kettering, OH 45429

**Factory Build Records:** Joel Rosen, \$10 TR2-3-3A  
833 Rampart Way, Union Bridge, MD 21791

**Technical Video Coordinator:** Jim Johnson, 614-756-4972  
5910 Brook Rd., NW, Baltimore, OH 43105

**TR Mart:** Jim Johnson, 614-756-4972  
5910 Brook Rd., NW, Baltimore, OH 43105

Frank Ciboch  
879 Heatherstone Dr., Cincinnati, OH 45240



# NATIONAL NEWSLETTER

**NATIONAL NEWSLETTER** is the official publication of the **TRIUMPH REGISTER of AMERICA.**

---

**PLEASE NOTIFY TRA OF ADDRESS CHANGES AS SOON AS POSSIBLE!**

*Please send address updates to:*

TRA  
5650 Brook Road, NW  
Lancaster, Ohio 43130

---

---

## On the Cover

3rd generation TR enthusiast Christen Richards tries out the Occasional seat. I think she would rather be in the driver's seat.

---

---

Advertising policy: TRA does not at this time have a commercial advertising rate, but does publish commercial information, of interest to the preservation of the TR2-4 series, as a service to its members. Classifieds are free to members

---

---

Information found within this newsletter is believed to be correct and of interest to the sidescreen TR owner. Opinions expressed may or may not reflect the ideas of all officers and members. Technical material is provided for your reference and should be used at your own risk.

## STAFF

**NEWSLETTER EDITOR:** John Hartley  
231 W. Washington Street  
Nelsonville, OH 45764  
614-753-1066

**TECHNICAL EDITOR:** Robert Schaller  
12021 North 30th Place  
Phoenix, AZ 85028  
602-992-7969

**WESTERN CORRESPONDENT:** Martin Lodawer  
20929 Lassen Street #112  
Chatsworth, CA 91311  
818-998-5753

## From the Editor!

Announcing TRA's new Coeditor:

*John Huddy*  
324 E. Stanton Ave.  
Columbus, Ohio 43214  
1-614-846-2321

John, a longtime TRA member and President of COCTRA is the newest member of the *National Newsletter* staff.

John will be keeping the local center listings current, listing upcoming events and taking care of advertising.

Please submit your classifieds and updated club information along with events of interest to our membership to John.

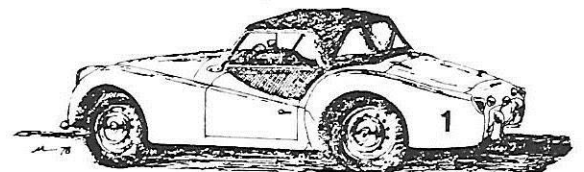

# President's Message

It was August 19, 1973, and the 16th birthday of my oldest son, Nino. We celebrated not only his birthday and driver training permit, but the completion of restoring his birthday gift, a lacquer red TR3B. This car was purchased the year before in Greensburg, Pennsylvania, and we spent nearly every evening and weekend working on this rusted and tired little TR.

With this TR project finished and Nino out showing it off to everyone, I was like a fish out of water--I found I had nothing to do. Without much convincing, Barb agreed that I should find another TR to build for me and the search was on. I should have been more selective and not in such a rush in choosing my next project for the TR I towed home was not only collision damaged, but rusted and patched with the patches rusted as well. I finally realized it was too bad to restore. Since parts for Nino's car had been so difficult to find, I decided to parts out this car and find a better project. A "TR Parts for Sale" ad was placed in the local trading paper which put me in contact with 36 other TR owners. This list was the start of Triumph Register of America.

The past twenty years of TRA have been both rewarding and exciting ones for me. The availability of parts has improved beyond anyone's expectations. I can remember when at the 1976 National Meeting, a member of the host club PACTRA was able to transport a few new parts from England in the luggage of an airline stewardess. There was so much interest in purchasing the set of hubcaps and two trunions that a lottery was held just to determine who could participate in the auction. Spares have now become so available that parts suppliers, such as The Roadster Factory, can provide almost anything to maintain your car--even the ten cent clip or clamp that would cost more to pick and ship than the part is worth. TRA and their 16 local centers may not be totally responsible for this, but we certainly did influence it.

TRA also has available services, such as the Video Technical Library which is free to all members except for postage; Factory Build Records for only \$10; TRA NATIONAL NEWSLETTER completely dedicated to TR's and their owners; TR Mart with a selection of Triumph apparel and memorabilia; JUDGING STANDARDS AND RESTORATION GUIDELINES manual, the most complete information source available anywhere on originality for the TR2/3; TRA Concours which provides the best specimens of restored Triumphs in the Country, and the National Meet which has the best and friendliest people anywhere.

All of this must continue even though I cannot. My personal commitments and circumstances started the search for a new TRA President several years ago. The right person required knowledge of our cars, enthusiasm, commitment to TRA goals, and the ability to continue the growth of TRA. John Warfield satisfies all of these requirements.

John has been a member of TRA for 7 years and is very active in the Mason-Dixon local center. He restored a TR3A with uncompromising detail to earn "Best of Show" in 1991. John has coauthored the JUDGING STANDARDS AND RESTORATION GUIDELINES manual and is always willing to talk TR with anyone. His integrity, enthusiasm, and commitment to our hobby will provide TRA with a great President.

I personally thank all of you for your support these past twenty years.

# Schaller Engineering

12021 N 30th PLACE  
PHOENIX, ARIZONA 85028  
602-992-7969

Dear John,

The TR3 top has always been an annoyance with its penchant for ballooning up away from the front top bow. That takes all the pressure off the front bow and it can rattle its little head off, besides the stretching of the top fabric does not promote long life.

About six years ago I had my upholstery friend stitch lengths of VELCRO strips across the under side of the top and when up and fastened it very effectively prevents the ballooning and maintains pressure on the bow and stops the rattling. The sketch shows the detail of the fix.

Bob Schaller  
20 June 1994

## TR 2-3 ANTI-BALLOON FIX

BOB SCHALLER

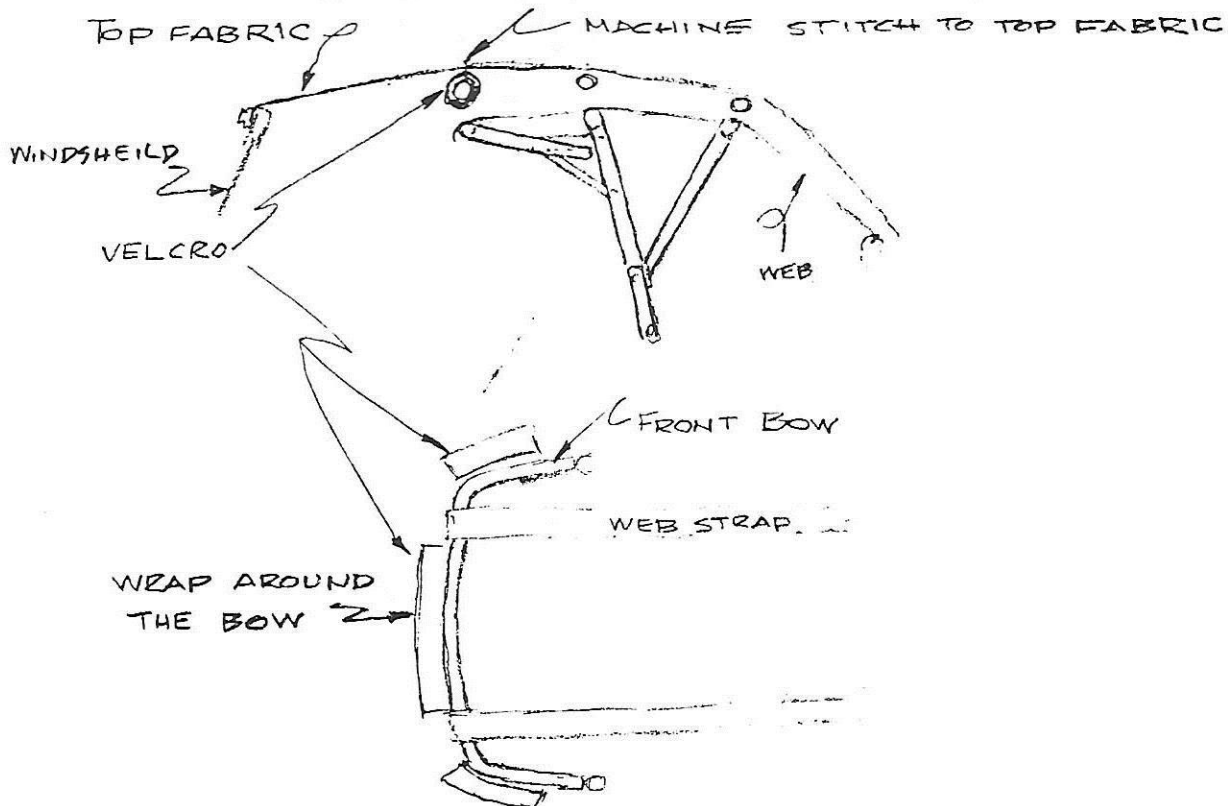



Occasional Seat TR3A Pre 60,000

#### OCCASIONAL SEAT

The accessories section of STANDARD TRIUMPH MOTOR COMPANY TR 2-3 SPARE PARTS CATALOG lists such options as heater, rear wheel cover kit (fender skirts), fitted suitcase and occasional seat. Now that the TR 3 is near 40 years old, the occasional seat like some of the other options that were offered are desired by many because they are somewhat unique, improve the appearance of the car, and are functional. The occasional seat is appreciated most by passengers who are less than 3 feet, 6 inches tall, otherwise, they are a little cramped. They do, however, improve the appearance of the interior, especially on the pre TS-60000 cars with the slant rear floor. The wider gas tanks used on TR 2 models prevented the use of a rear seat, but they were available for all TR 3 thru TR 3B models.

There are three different types used: The TR 3 (TS 8637 to TS 22013), which had a paper board front gas tank casing (cover), consisted of a cushion board to sit on and a squab board to protect the not so stiff paperboard gas tank cover. The TR 3A pre TS-60000 had a different set of mounting brackets and used only a cushion board. The upholstered front gas tank casing, which was more rigid than the early cars, served as the squab (back rest). The later bodied TR 3A and the TR3B had a boxed shelf for the rear floor and did not require brackets or a squab. Although many used this later floor style as an occasional set, there was a padded cushion board available to provide some comfort and further reduce head room with the hood (top) in place.

Here are the plans to make an occasional seat for your TR. It will be easy enough to construct with readily available materials. Probably the most difficult task will be finding a vinyl or leather covering to match your existing interior.

Good luck, call if you have any questions and let us know how it turns out.

Joe Richards

**OCCASIONAL SEAT  
BRACKET TR3**

TS-8637 TO TS-22014  
2 Pcs. 1/4 x 1 x 28 1/2" Flat Stock  
Finish - Painted Beige

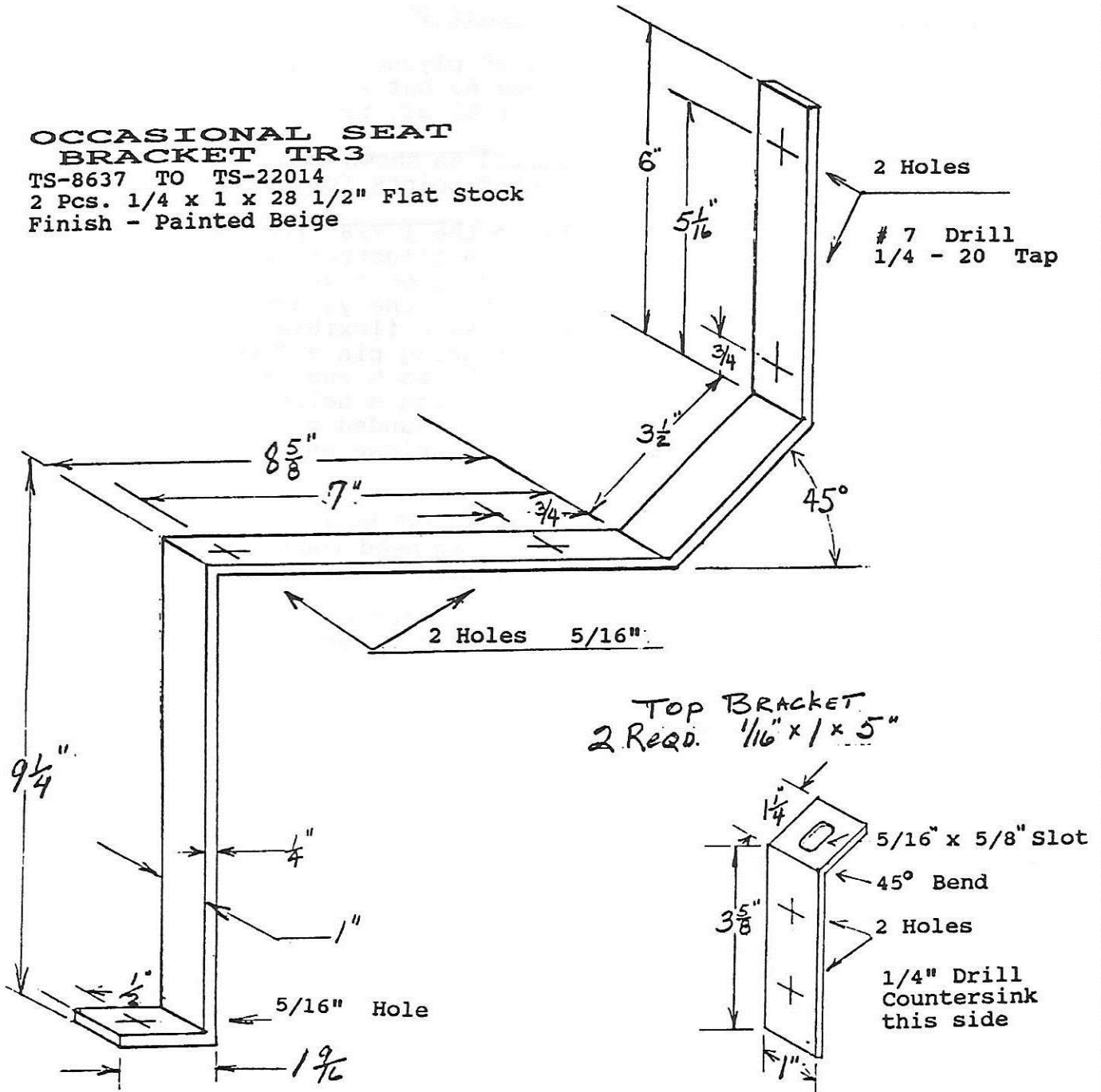

The 1/4 x 1" flat stock will probably require some heat from a torch to make the bends required. Even then the corners will not be as sharp as the drawing illustrates, and they are not supposed to be.

OCCASIONAL SEAT SQUAB (BACK) TS-8637 TO TS-22014 TR-3

The seat back is constructed of 3/8" plywood, 14" x 33 7/8". this size is slightly larger than is needed but will make construction easier. The 33 7/8" dimension is critical, measure it carefully.

- Step 1. Mark plywood with pencil as shown on illustration "D". Points 1 & 2 are center points for 1 7/8' Radius.
- Step 2. Use a compass or trace the 1 7/8" radius. Drive in a Locating Pin as shown in illustration "E". (Note: 1" finishing nails work well, only drive them in about half way so that they hold the yardstick secure and are easy to remove). Take a flexible yardstick, place the 18" mark on the locating pin and bow both ends (similar to a kite stick) to blend with the corner Radius on both corners. With a helper trace along the inside edge to meet both rounded corners. THIS WILL NOT BE EXACT, but will be close enough to freehand a graceful top edge.
- Step 3. Layout and drill the 4 - 1/8" holes (illus. E). These are pilot holes for 4 flat head wood screws to fasten the upper bracket to squab.
- Step 4. Layout and drill the 4 - 1/4" holes (illus. E). Now countersink these holes to accept a 1/4" - 20 flat head machine screw.
- Step 5. Layout the 3/8" Radius on lower corners to avoid ripping cover material when installed. ( Drawing a 3/8" Radius on plywood is better done by using a copper Penny and tracing around it.
- Step 6. Cut out squab with a jig saw or whatever else you may have. Sand rough edges and paint both sides flat black.
- Step 7. Fasten Squab board to iron brackets using 4 flat head 1/4"x20 screws. The iron brackets will be on the upholstered side of the board.
- Step 8. Spot cement a 2" foam cushion cut to size to the board, and install vinyl or leather seat cover with tacks or staples. Iron brackets are installed to board before padding and cover is installed. You must upholster around iron brackets. Install the 2 upper brackets with appropriate flat head wood screws.



# OCCASIONAL SEAT SQUAB

TS-8637 TO TS-22014 TR 3

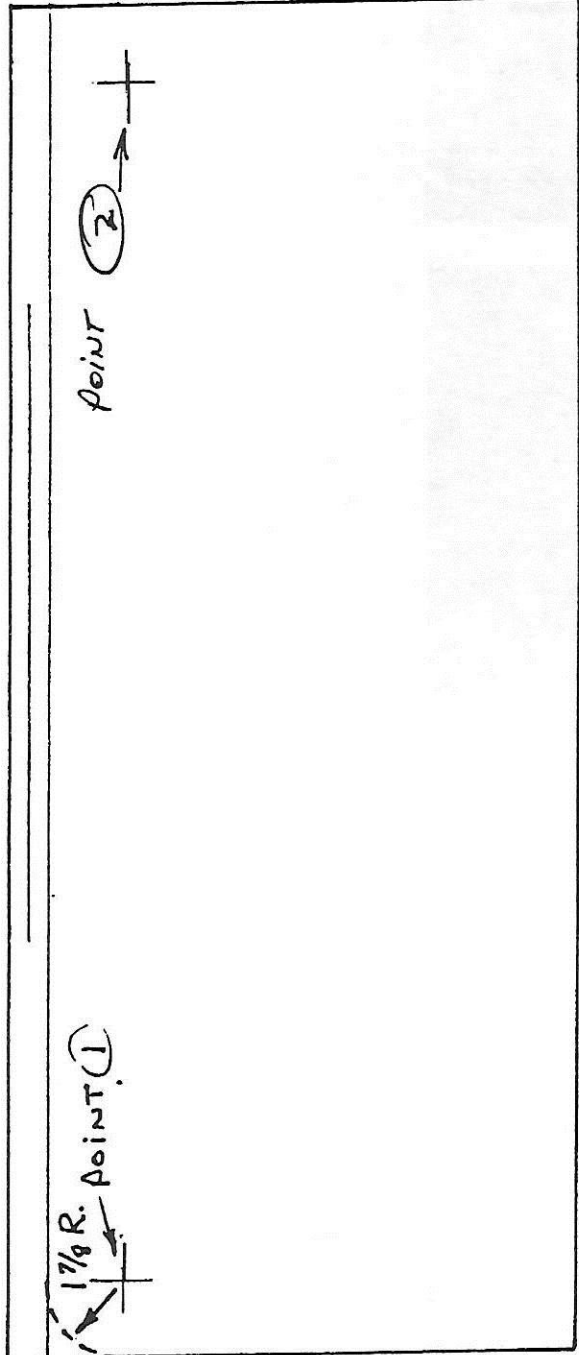
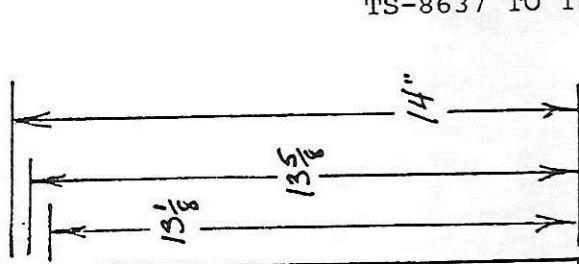

ILLUSTRATION D

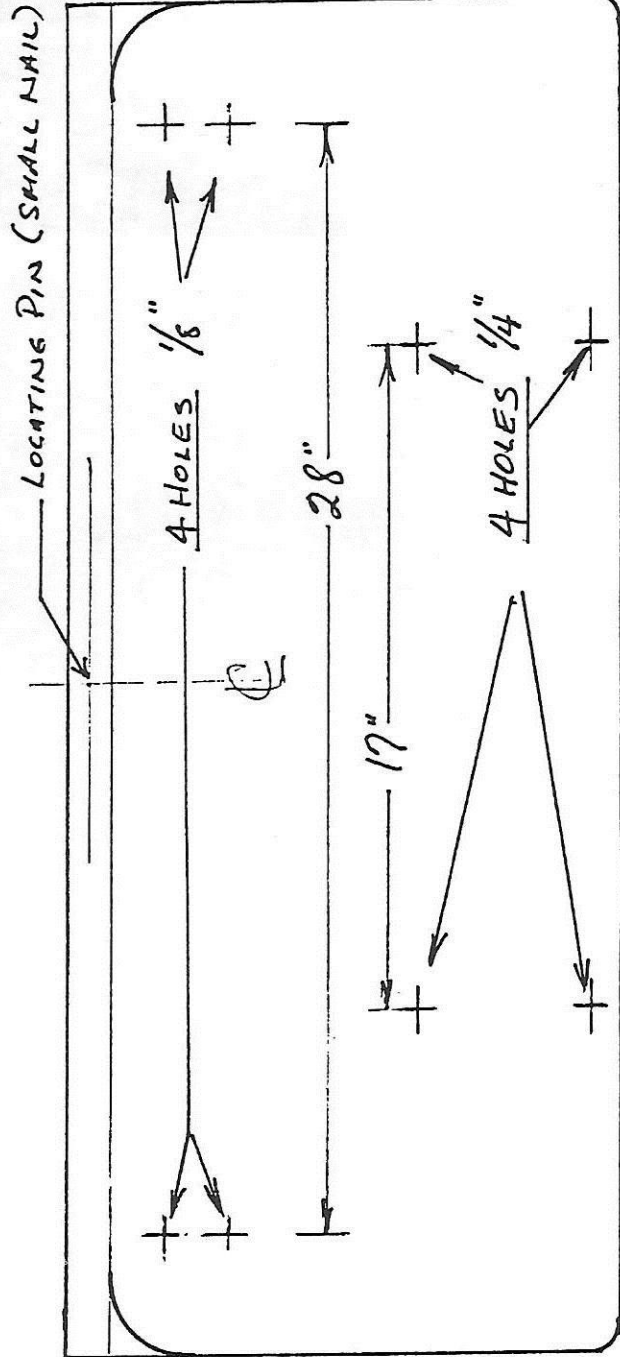
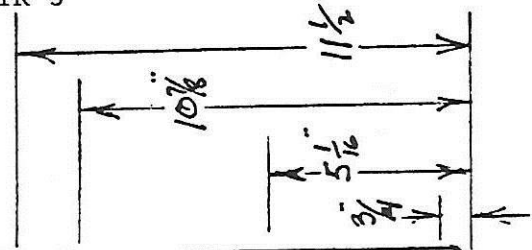
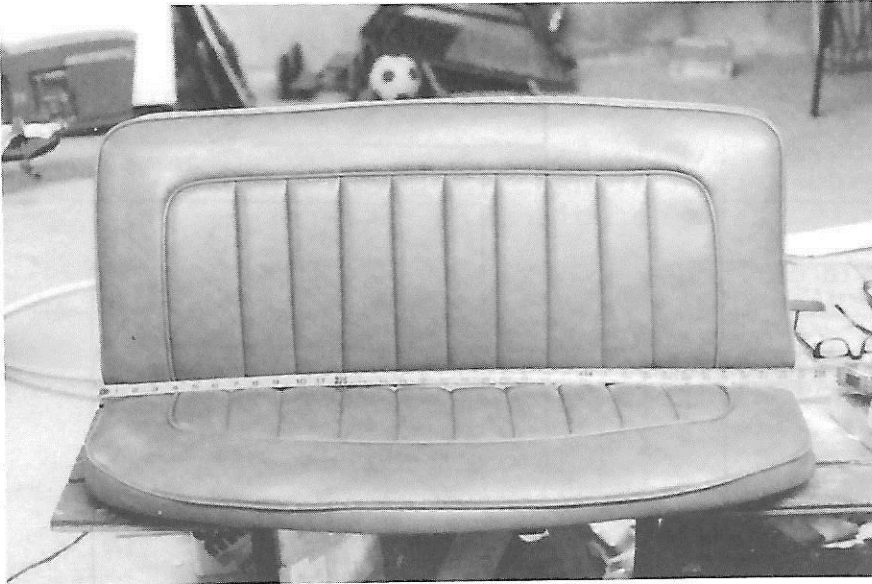

ILLUSTRATION E



*TR3 rear occasional seat with squab.*



*Tee nuts should be secured with small screw before covering.*

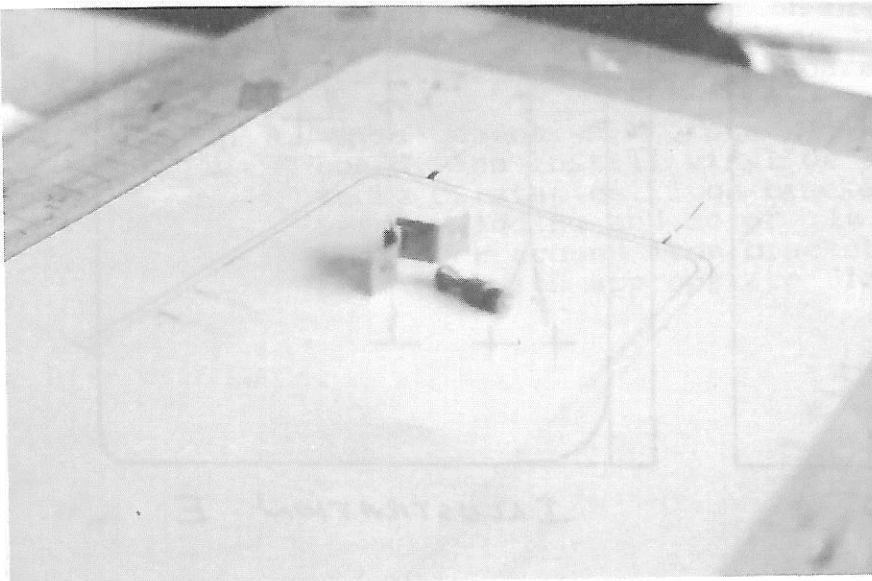

*Clips used to hold TR3A 60,000 + seat from sliding.*

SEAT CUSHION TS-8637 TO TS-60000

The Seat Cushion for TS 8637 through TS 60000 is the same except for the location of the Tee Nuts on the TR3A (See NOTE). Dimensions shown on PATTERN "A" are for TR3. The cushion is constructed of 3/8" plywood, 12" x 34". This size is slightly larger than needed but will make construction easier.

- Step 1. Cut out PATTERN "A" and trace on plywood as shown on illustration "B".
- Step 2. Locate center of plywood and mark 2-3/8" Radius. This should be 1-1/8" deep and 4" wide as per illus. "B".
- Step 3. A flexible yardstick will help to complete the pattern for the Cushion board. Drive 3 small nails into the plywood (Note: 1" finishing nails work well, only drive them in about half way so that they hold the yardstick secure and are easy to remove). Bow the yardstick around the 3 nails to complete the pattern for the front edge of the seat. With a helper trace along the inside edge of the yardstick to meet the edges of pattern "A". THIS WON'T BE EXACT, but will be close enough to freehand a graceful front edge.
- Step 4. Cut out plywood with jig saw or whatever else will work. Be sure to round corners of plywood, (approx. 3/8" Radius), to avoid ripping vinyl or leather cover. Sand rough edges, and paint both sides flat black.
- Step 5. Illustration "C": Mark location of the 4 TEE NUT holes and drill to appropriate size, probably 3/8". The head of the TEE NUT should be on the upholstered side of the plywood. It is a good idea to place a small screw next to the head to keep them in place after board is covered.

**NOTE:** On the TR3A seat the 3/4" dimension (Seat Cushion Figure "C") should be 3 1/4", and the 7" dimension should be 7 1/2".

- Step 6. Cut 2" foam rubber to fit outline of seat cushion but allow 1 1/2" excess at rear of cushion. When upholstered this will fill the irregular floor surfaces behind seat.



*Using yardstick as an adjustable French curve.*

*Helper marks the cut line.*

# SEAT CUSHION

TS-8637 TO TS-60000  
TR 3 & TR 3A

## PATTERN "A"

Pattern "A" is to scale and should be traced or copied carefully. Check height & width dimensions as shown in Fig. "B".  
8" width x 9 1/2" height

FIGURE "B"

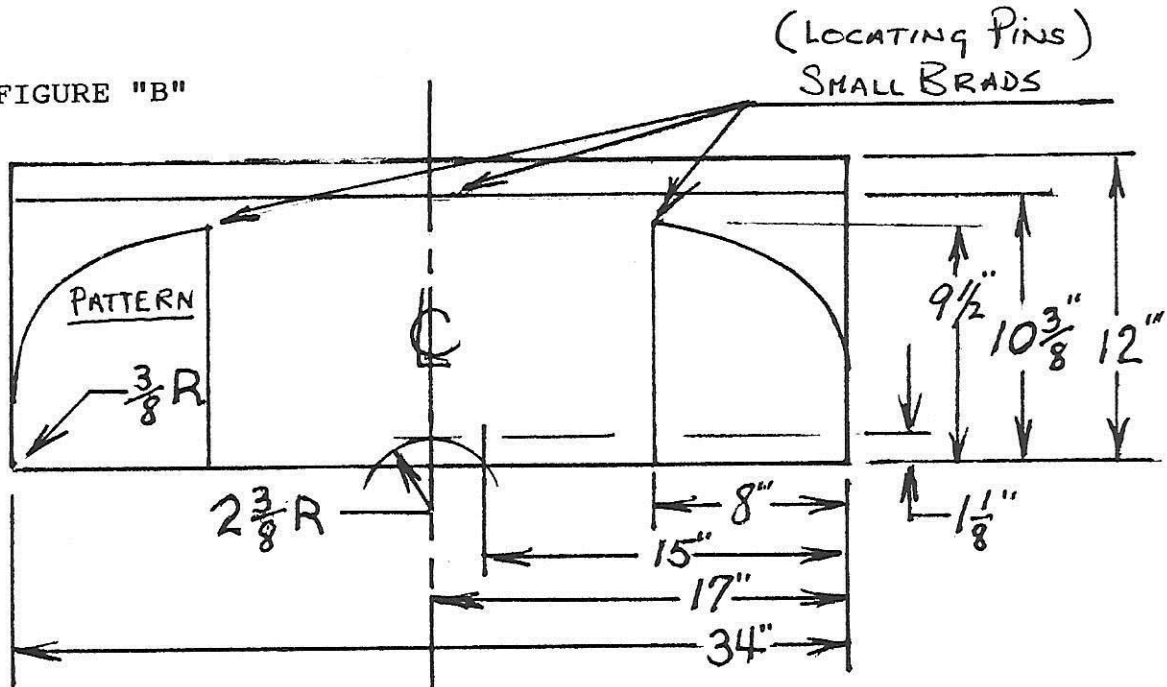
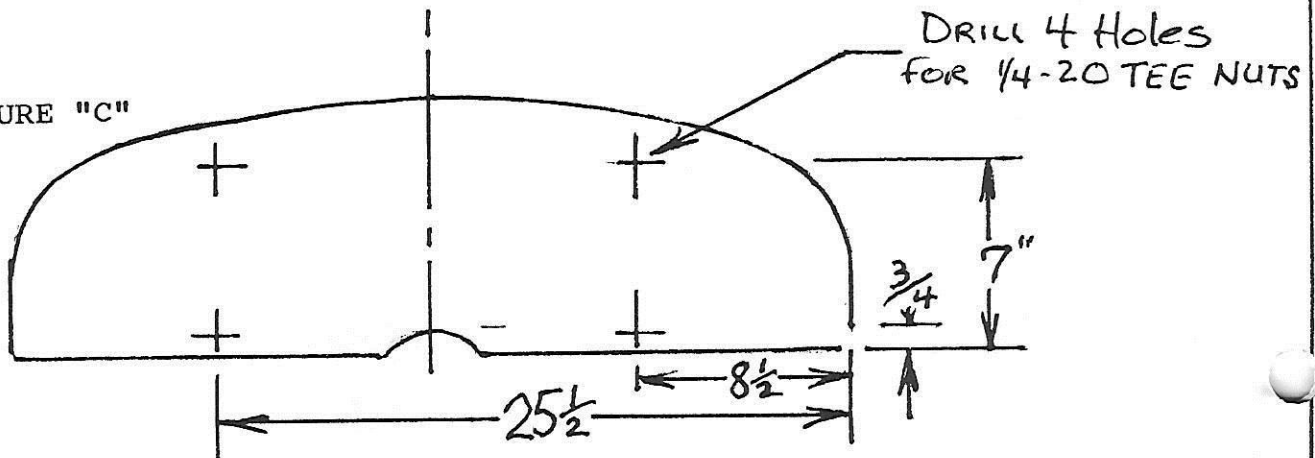
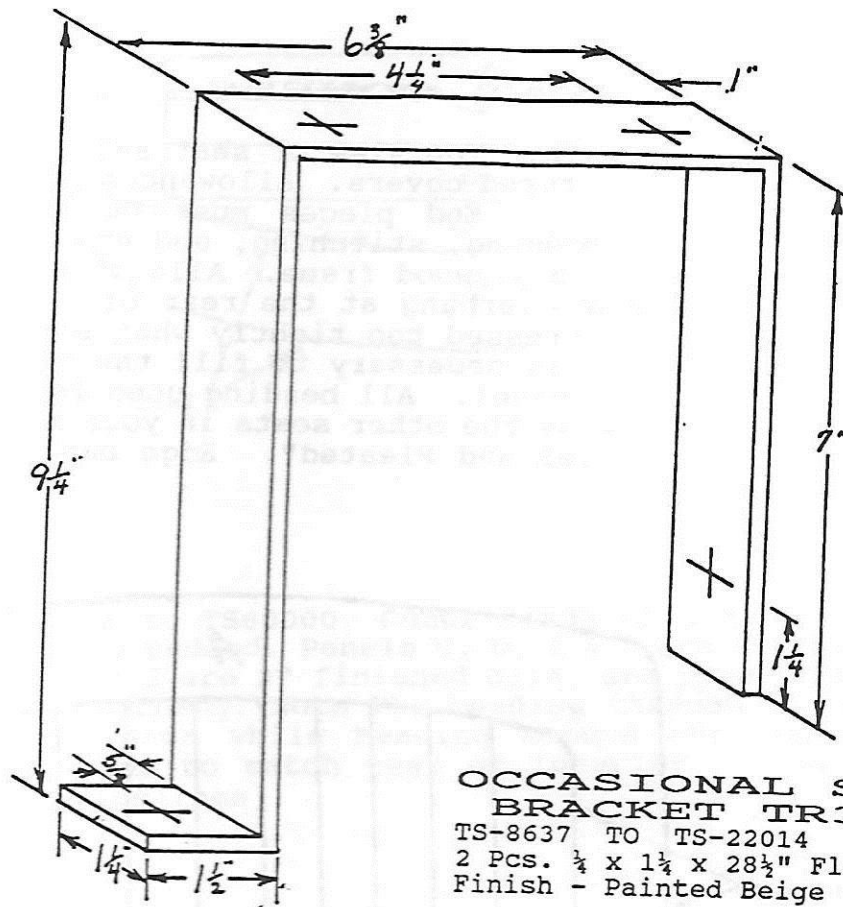

FIGURE "C"





**OCCASIONAL SEAT BRACKET TR3**  
 TS-8637 TO TS-22014  
 2 Pcs.  $\frac{1}{4}$  x  $1\frac{1}{2}$  x  $28\frac{1}{2}$ " Flat Stock  
 Finish - Painted Beige

TR3 A Post TS 60000, TR3 B  
 Seat frame is constructed from  $\frac{3}{4}$ " plywood  $12$ " x  $33$ ". The corners are rounded slightly to prevent the sharp corners from tearing the upholstery fabric. The relief for the floor hump at the rear of the seat is  $5$ " wide and  $2$ " deep. It has 2  $\times$   $1$ " holes bored to receive the spring hold down clamps. A strip of velcro tacked to the bottom of the seat board grips the carpet well enough to hold the seat in place while driving. The Foam rubber pad is cut about an inch oversize on the front and both sides, and  $1\frac{1}{2}$ " on the rear edge.

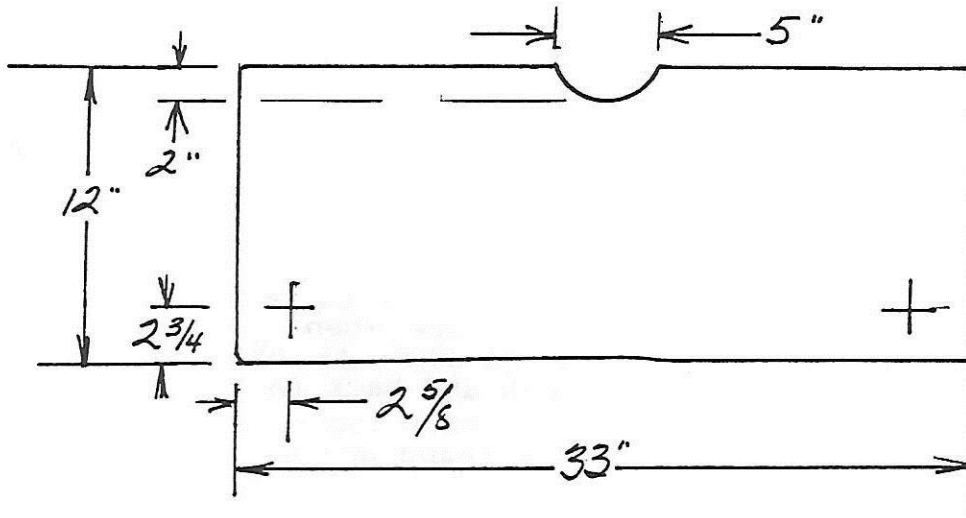

## SEAT COVERS

Illustrations Not to Scale: Top view of seat and back panels are to show pattern of upholstered covers. Allowances must be made for stitching parts together. End pieces must be wide enough to accommodate the 2" foam padding, stitching, and enough material to tack or staple material to plywood frame. Allowances must also be made for the foam rubber overhang at the rear of the seat. This overhang must not be compressed too tightly when stretching cover over plywood frame as it is necessary to fill the gap between the seat bottom and the back panel. All beading used is 1/8", and the color scheme is the same as the other seats in your model car. All center inserts are "Rolled and Pleated". Edge bands "A & B" are lightly padded.

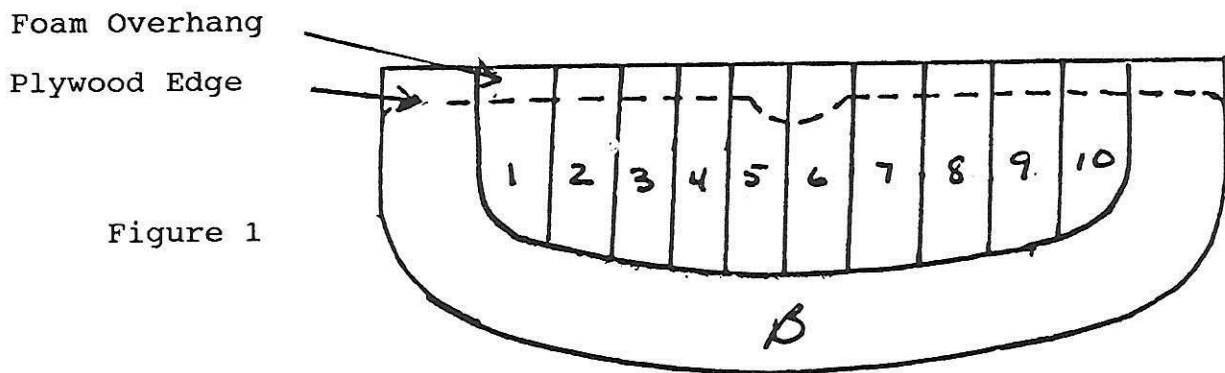
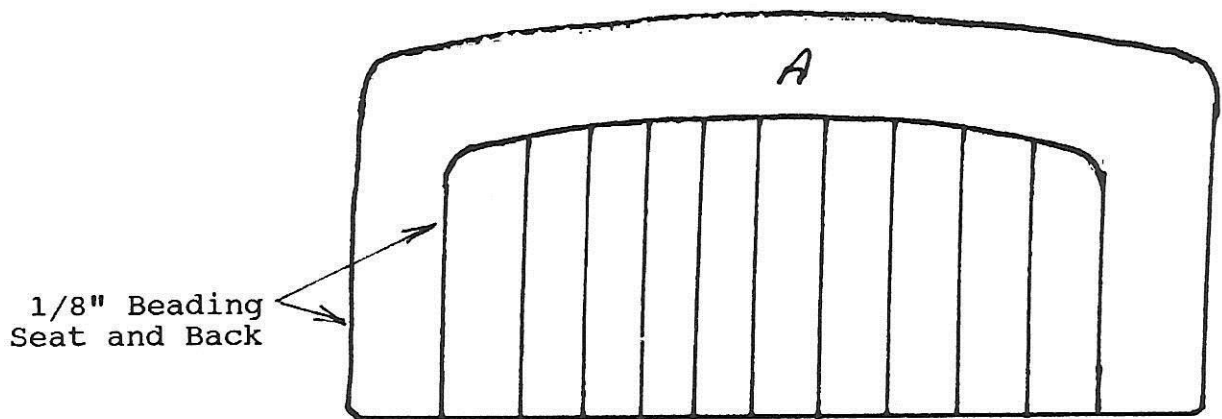

Figure 1 Inserts #1 & #10 are 3" wide when stitched to other panels (finished size). Inserts #2 thru #9 are 2½" wide when finished. The outer band on the seat and back (A & B) is 3½".

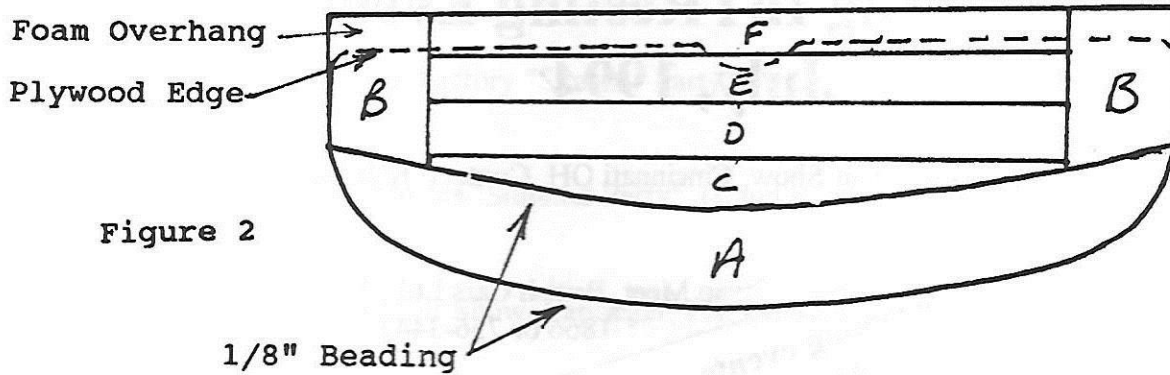

Figure 2

Figure 2 TR 3A to TS60000 Outer bands (A & B) are 3½" finished size and lightly padded. Panels C, D, E & F are Rolled and Pleated. Panels C, D, and E are 2" finished size, and panel F is 5" to allow for the foam overhang. Note The beading through the center of the seat is seat color while beading around the edge is white or contrasting color to match rest of interior, (See Concours and Restoration Guidelines).

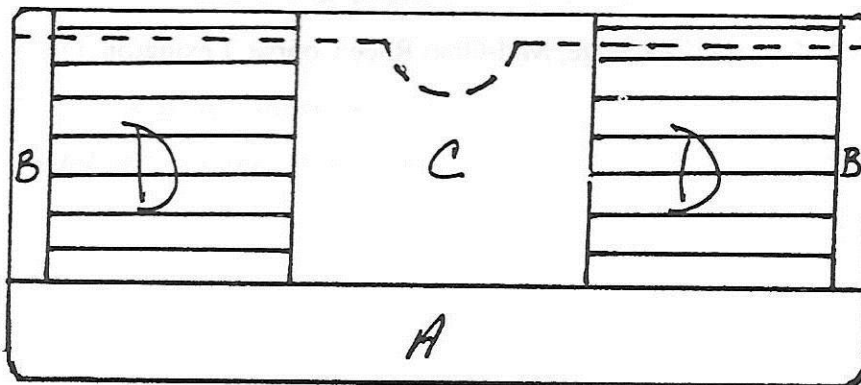

Figure 3

Figure 3 TR3A post TS 60000 Outer band A is 3½"x 35½" when finished. Panels B are 1½"x 12" wide when finished. Panel C is 12"x 12" when finished. Panels D are 10"x 12" and are Rolled and Pleated. Beading through the center of the seat is seat color. Beading around the outer edges may or may not be there. I have 2 occasional seats and both seem to be original and neither seat had beading around the outer edge. Other reliable sources say that there should be beading around the outer edge. If the outer beading is used it should be white.

# Upcoming InTResting Events: July, 1994

**July 10th,** Greater Cincinnati British Car Show, Cincinnati OH, Contact: Bob Merten, (513) 662-9159.

**July 10th,** "British Car-Niv OH, Noon to 4:00 P.M., C

**July 10th,** Fifth Annual " hosted by the New Engl MA, 02184, (617) 843-

**July 17th,** British Car Day, Dearborn, MI, Contact: Stuart Rigler, (810) 589-9028.

**July 21st-24th,** North American MGA Register GT 19, Winston-Salem, NC, Contact: Dave Smith, (517) 694-4856.

**July 23rd,** "Tea at the Vicarage", on the Campus of Howe Military School, Northern Indiana, Contact: Philip Morgan, (219)562-2703.

**July 28th-31st,** Ninth Canadian Classic, Belleville, Canada, Contact: Toronto Triumph Club, c/o Grant Buss, 943 Hortop Court, Oshawa, Ontario, Canada, L1G 4R2, (905) 576-0817.

**July 29th-30th,** Mid-Ohio Historic Challenge, Mid-Ohio Race Course, Lexington, OH, Contact: Joe Pendergast, (813) 931-5642.

**July 29th-31st,** "Summer Carlisle", Collector Car Flea Market & Corral, Carlisle, PA, Contact: Carlisle Productions, (717) 243-7855.

**July 31st,** British Car Day and Swap Meet, Nelson Ledges Road Course, Garrettsville, OH, hosted by the North Coast Triumph Association, Contact: Bob and Cindy Palmer, (216) 274-0017, or Darrell and Bev Floyd, (216) 666-2817.

## August, 1994

**Aug. 3rd-7th,** Vintage Triumph Register National Convention, Asheville, NC, Contact: Jamie Palmer, (919) 639-4907.

**Aug. 6th,** British Car Day, Cleveland, OH, Contact: Tony Burgess, (216) 357-5378.

Upcoming events should be submitted to:  
John Huddy  
324 E. Stanton Av.  
Columbus Ohio 43214

Swap Meet, British Cars Ltd., 335 Park Ave., Mansfield, OH, (513) 1866 or 756-3447.

Worcester, MA,  
36 Maple Street, Braintree, MA, (617) 843-1000 P.M. only).

World Car Museum, Contact: (513) 662-9159.



**Aug. 6th**, 10th Annual British Car and Cycle Day, Dayton Art Institute, Dayton, OH, Contact: Jim Quillen, (513) 252-1948.

**Aug. 12th-14th**, The Roadster Factory "Summer Party", Armagh, PA, Contact: Dana Henry, (800) 678-8764.

**Aug. 19th-21st**, University Motors "Summer Party", Grand Rapids, MI, Contact: John Twist, (616) 245-2141.

**Aug. 28th**, "Taste of Britain" Car Show, Lancaster, PA, Contact: Ray Emery, (717) 872-7528.

## September, 1994

**Sept. 3rd-4th**, All British Meet, Kansas City, Contact: Larry Dickstein, (816) 356-6053.

**Sept. 11th**, British Car Day, Palo Alto, CA. Contact Rick Feibusch, (310) 392-6605.

**Sept. 11th**, "Battle of The Brits", Sterling Heights, MI, Steve Calkins, (810) 268-9495, or Jack Fuller, (810) 553-8738.

**Sept. 11th**, British Car Festival, Des Plaines, Chicago, IL, Contact: (?), (708) 885-7789.

**Sept. 11th**, Third Annual British Car Show & Swap Meet, Chesterland, OH, sponsored by the North Coast Triumph Association, Contact: Don Evans, (216) 234-2410, or Darrell Floyd, (216) 666-2817.

**Sept. 17th**, Moss Fall Classic All British, Moss Motors, Goleta, CA, Contact: (?), (800) 235-6954.

**Sept. 17th-18th**, British Car Conclave, Arvada, CO, Contact: Brian Serff, (303) 750-5746.

**Sept. 25th**, Indy British Motor Day, Conner Prairie Settlement, north of Indianapolis, Contact: Brett Johnson, (317) 849-2001.

**Sept. 29th-Oct. 2nd**, "Triumphest 94", San Diego, CA, Contact: Dave Johnson, (619) 693-0443.

**Sept. 29th-Oct. 2nd**, "6-Pack" Trials, Richfield, OH, Contact: Beverly Floyd, (216) 666-2817.

**Sept. 29th-Oct. 2nd**, "Fall Carlisle", Collector Car Flea Market & Corral, Carlisle, PA, Contact: Carlisle Productions, (717) 243-7855.

**Sept. 30th-Oct. 2nd**, 13th Annual British Car Festival Weekend, P.O.Box 323, Waynesboro, VA, 22980, Contact: Roger Hammond, (703) 337-4652 (Home) or (703) 886-0500 (Work).

## Classified Ads:

**For Sale:** TR-4 Race Car, SCCA Log Book. Last raced in 1976. Right hand drive, overdrive transmission, Detroit Locker, all performance modifications. Very straight and original. Excellent vintage race car. \$3,995

Parting out TR-3's and TR-4's. Lots of engine, transmission, suspension, brake parts, etc. TR-4 frame, reasonable prices.

If interested in the above car or parts, please contact: Jack Wheeler, 336 Fairmount Dr., Madison, IN, 47250. (812) 265-4974.

**For Sale:** Master Battery Switches, \$10 each plus postage. Fits any TR-2 or TR-3 and most any other car or truck. Eliminates battery drain, electrical fires or unauthorized use.

Contact: Walt Sweyer, 1717 NW 414th Street, Woodland, WA, 98674. (206) 225-7562.

**Wanted:** T.R.A. member is seeking "driver or better" TR-3. Optimal car is equipped with overdrive, wire wheels, tight power train and no more than 30K on engine since overhaul. Car must not have frame damage or rust and paint must be in very good to excellent condition. Prepared to take possession at The Roadster Factory "Summer Party". Contact: Allan Johnson, 1305 Norhview Road, Baltimore, MD, 21218-1446. (410) 366-3269 (Home), (410) 887-4321 (Work) or (410) 887-7830 (Fax).

**Wanted:** Long shaft steering box for right hand drive TR-2. Guts not important. Need good case, but will consider any condition. Call: Joseph Zimmerman at (410) 643-4392 (evenings).

**For Sale:** 1962 TR-3B "basket case", all or part, excellent tub and frame, overdrive transmission. Ask for Mel Wallace at (313) 274-6876.

**Classified Ads** should be submitted  
to:

John Huddy  
324 E. Stanton Av.  
Columbus Ohio 43214

# "LOCAL CENTERS"

**Central Ohio Center / TRA**

John J. Huddy, Pres. (614) 846-2321  
324 E. Stanton Ave., Columbus, OH 43214

**Delaware Valley Triumphs**

Lyle J. Edlin, TRA Rep. (215) 368-0481  
2090 Pheasant Hill Rd., Lansdale, PA 19446

**Desert Center / TRA**

John Lindly, Newsletter (602) 581-2763  
2146 West Montana Drive, Phoenix, AZ 85027

**Mason Dixon / TRA**

John D. Warfield, Pres. (410) 974-6707  
934 Coachway, Annapolis, MD 21401

**Miami Valley Triumphs**

Bruce Clough (513) 435-0106  
1082 Beryl Trail, Centerville, OH 45459

**Michigan TR Association**

Joe Germay (616) 327-9262  
9347 S. Westnedge, Kalamazoo, MI 49002

**The New England Triumphs**

Robert Lang, Newsletter (617) 438-2568  
58 Maple St., Stoneham, MA 02180

**North Coast Triumph Association**

Al Kelly, Pres., (216) 653-8472  
267 S. Main St., Hudson, OH 44236

**Western Pennsylvania Triumph Association**

Bill Kern, Newsletter  
150 Holiday Drive Pk., Pittsburgh, PA 15239

**Portland Triumph Owners Association**

David Duthie (503) 246-6687  
P. O. Box 14105, Portland, OR 97214

**Potomac Area Center TRA**

Jim and Claire Privitera (301) 544-1622  
1251 Timber Turn, Arnold, MD 21012

**Triumph Travelers Sports Car Club**

Russ Bush, TRA Rep. (510) 657-5234  
41411 Apricot Ln., Fremont, CA 94539

**Texas Triumph Register**

John Parr, Pres.  
P. O. Box 440460, Houston, TX 77244

**Triumph Register of Southern California**

Marty Lodawer, Pres. (818) 998-5753  
20929 Lassen St. #112, Chatsworth, CA 91311-4226

**Triumph Club of the Carolinas**

Robert Yokley, Pres. (910) 996-3825  
Kernersville, NC

**Triumph Club of North Florida**

Walt Lanz, Asst. Dir., (904) 646-0616  
1900 Kusaie Dr., Jacksonville, FL 32246-2423

*Please notify Asst. Editor, John Huddy, 324 E. Stanton Ave., Columbus, Ohio 43214 of any corrections or updates.*

*231 W. Washington St.  
Nelsonville, Ohio 45764*

*First Class Mail*

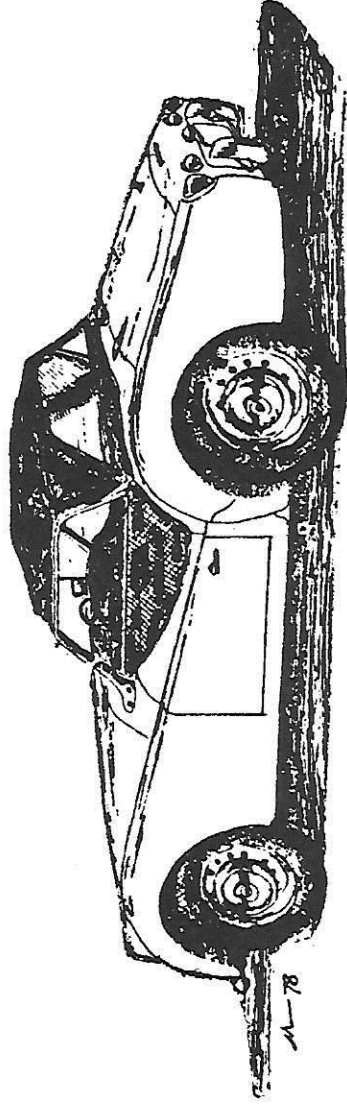

**TRIUMPH REGISTER of AMERICA**